

# AP B Belt Drive Positioning System



AP60B

AP80B

AP110B

AP166B

## Belt Drive Position System

Type : AP B

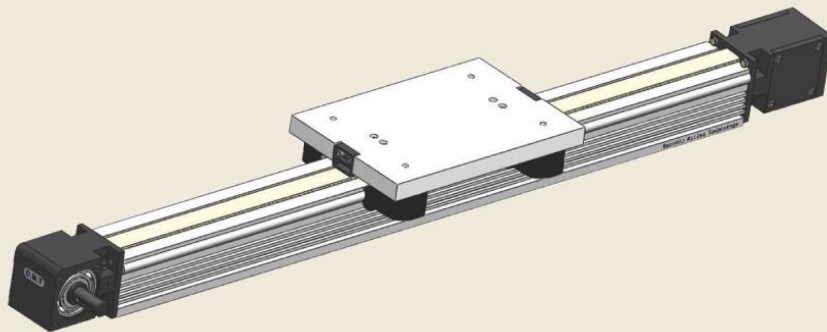

## Distinction

- Application : Main axis
- Principle of operation : Belt drive unit
- Material : Beam & Carriage plate – AL6061 profile  
Guide shaft – SUJ2  
Bearing Roller – Hardened steel
- Speed : Bearing roller based U slide system allows speeds in excess of 5~8 m/s
- Durable : Rugged construction – All steel hardened slideway—unique wiping action excludes debris
- Installation : in various position
- 적용 : 주행축용
- 구동원리 : 벨트 구동 형식
- 재질 : Beam & Carriage plate – AL6061 profile  
Guide shaft – SUJ2
- 속도 : 베어링 롤러의 U형 안내방식은 5~8m/s의 속도실현
- 내구성 : 슬라이드부는 열처리 강을 사용하며 와이퍼 장치는 불순물을 제거하여 수명을 향상 시킨다.
- 설치 : 다양한 위치 설치 가능



# AP B Belt Drive Positioning System

AP60B

AP80B

AP110B

AP166B

## Belt Drive System AP60B

Beam Size	Dynamic Force(N)	Max. Speed	Max. Length	Shaft Diameter	Roller Type	Belt Type	Pulley 잇수(z)	Cycle Distance	Repeat-ability
AP60	1,100	5m/s	4,000	φ 10	G10B	S8M-25	19	152mm/rev	± 0.2mm

### Dimension For AP60B

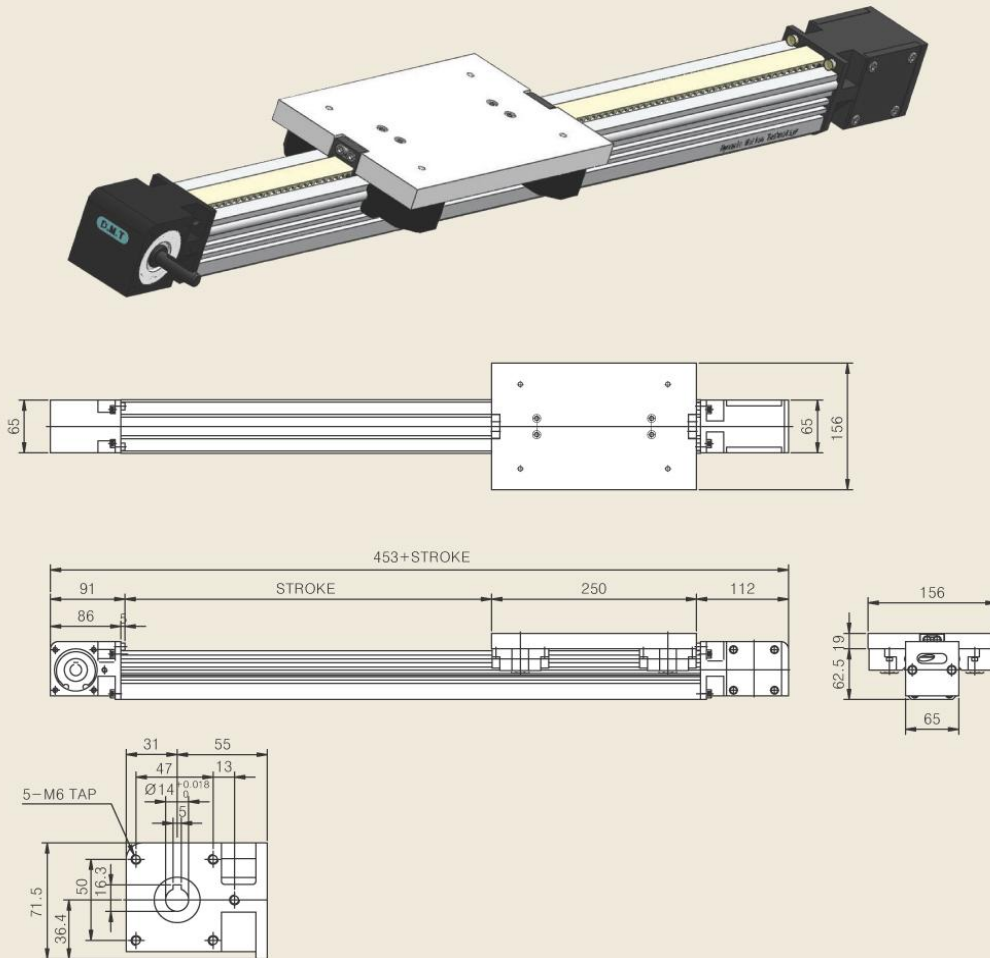

# AP B Belt Drive Positioning System



AP60B

AP80B

AP110B

AP166B

## Belt Drive System AP80B

Beam Size	Dynamic Force(N)	Max. Speed	Max. Length	Shaft Diameter	Roller Type	Belt Type	Pulley 잇수(z)	Cycle Distance	Repeat-ability
AP80	1,700	6m/s	5,000	φ 16	G16B	S8M-30	24	192mm/rev	± 0.2mm

### Dimension For AP80B

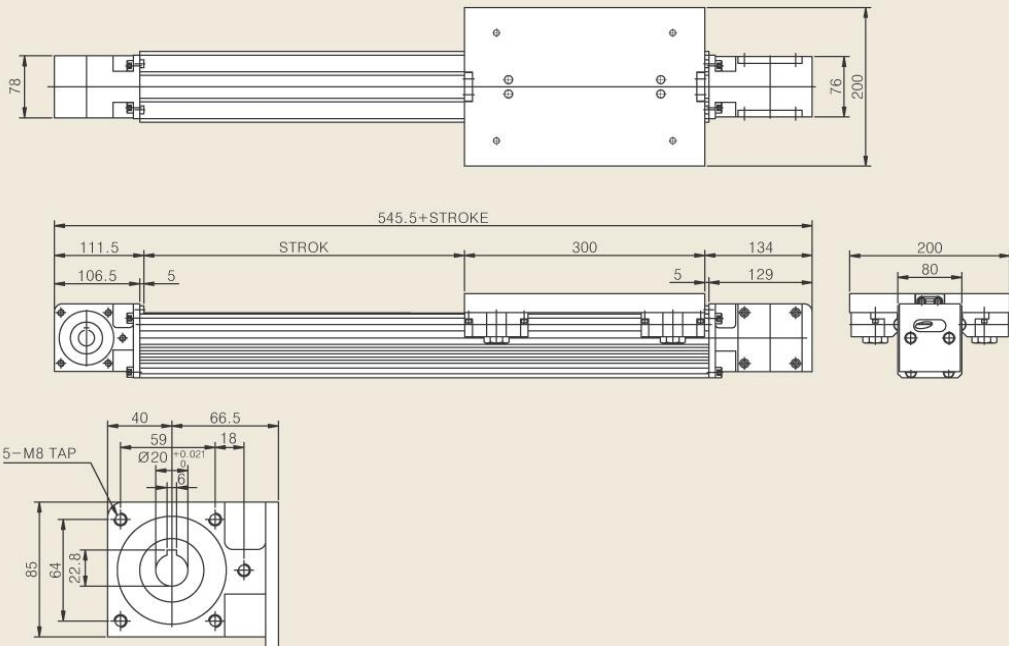
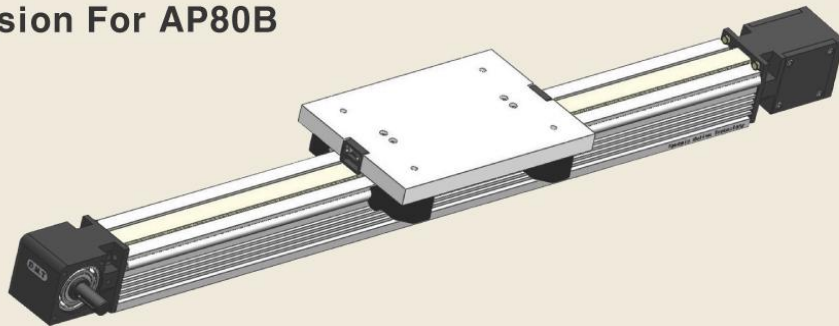



# AP B Belt Drive Positioning System

AP60B

AP80B

AP110B

AP166B

## Belt Drive System AP110B

Beam Size	Dynamic Force(N)	Max. Speed	Max. Length	Shaft Diameter	Roller Type	Belt Type	Pulley 잇수(z)	Cycle Distance	Repeat-ability
AP110	2,200	8m/s	5,000	φ 20	G20B	S8M-50	36	288mm/rev	± 0.2mm

### Dimension For AP110B

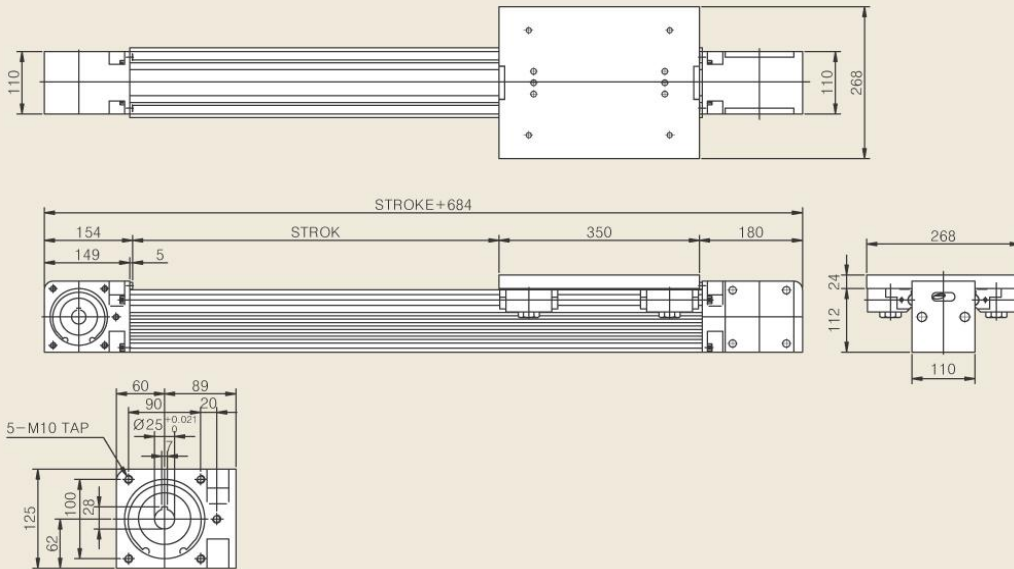
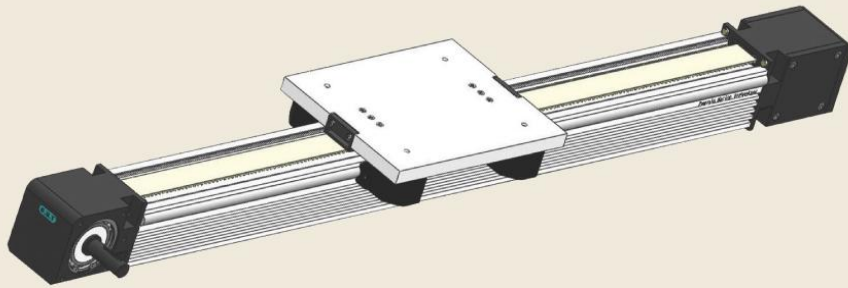

# AP B Belt Drive Positioning System



AP60B

AP80B

AP110B

AP166B

## Belt Drive System AP166B

Beam Size	Dynamic Force(N)	Max. Speed	Max. Length	Shaft Diameter	Roller Type	Belt Type	Pulley 잇수(z)	Cycle Distance	Repeat-ability
AP166	3,000	8m/s	5,000	φ 30	G30	S8M-50	40	320mm/rev	± 0.2mm

### Dimension For AP166B

