

## ●● 3GK Type

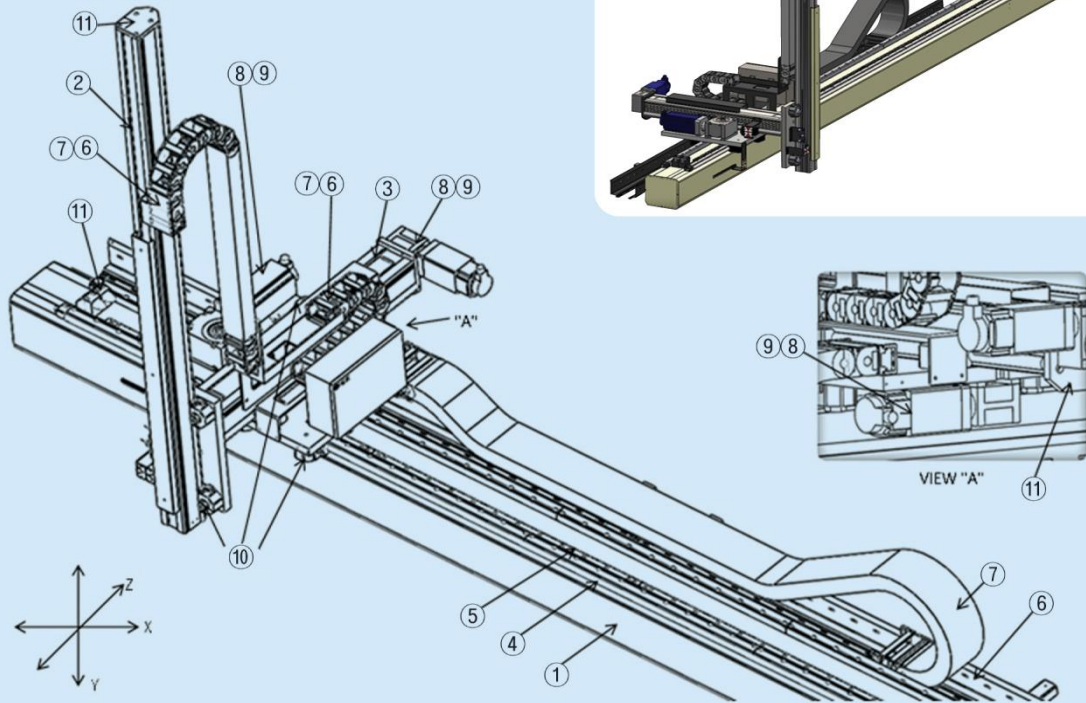

NO.	DESCRIPTION	STANDARD	OPTION
1	X-AXIS BEAM	●	
2	Y-AXIS BEAM	●	
3	Z-AXIS BEAM	●	
4	SHAFT HOLDER	●	
5	RACK GEAR	●	
6	CABLE BKT	●	
7	CABLE CHAIN	●	
8	WORM GEAR BOX	●	
9	SERVO MOTOR		●
10	GUIDEWAY ROLLER	●	
11	STOPPER	●	
*	POST		●
	OIL PAN		●

**3GK 15**  
15kg

**3GK 30**  
30kg

**3GK 60**  
60kg

## 3-AXIS GANTRY SYSTEMS TYPE : 3-AXIS K-TYPE

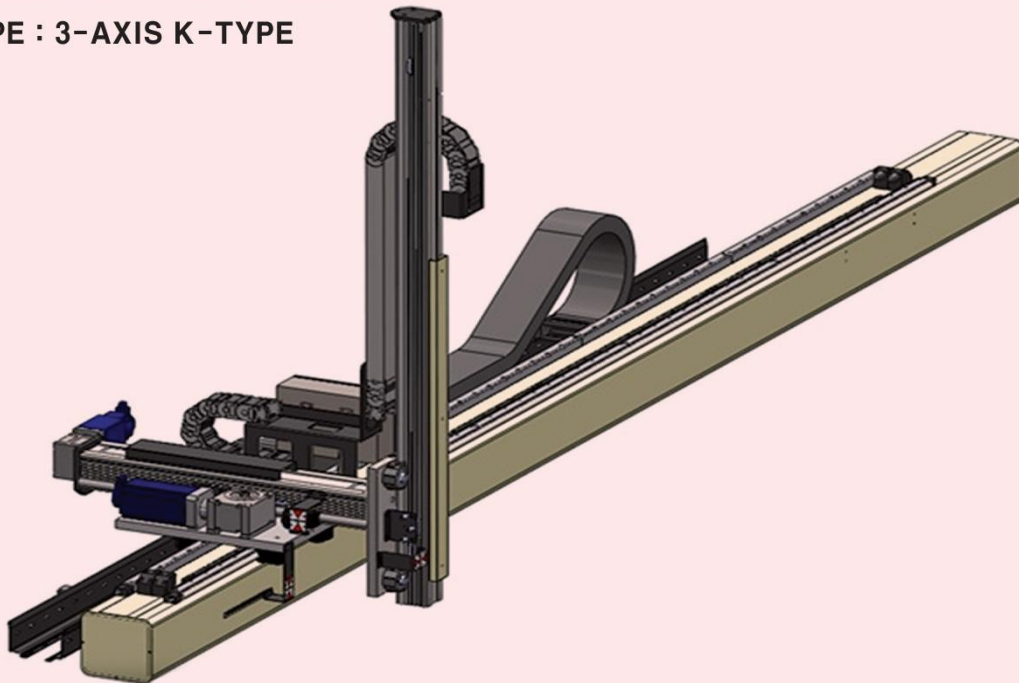

### Distinction

- |   |  |
|---|--|
| ▶ Principle of operation : Rack & Pinion<br>Timing Belt   | ▶ 구동원리 : Rack & Pinion<br>Timing Belt 구동형식   |
| ▶ Material : Beam - Square pipe<br>Up-down beam - AL6061 pipe<br>Carriage plate - AL6061                          | ▶ 재질 : Beam - Square pipe<br>Up-down beam - AL6061 pipe<br>Carriage plate - AL6061 |
| ▶ Speed : Bearing roller based U slide system<br>allow speeds   | ▶ 속도 : U형 안내방식에 의한 고속성 실현  |
| ▶ Durable : Rugged construction - All steel hardened and ground<br>slideway-unique wiping action excludes debris. | ▶ 내구성 : 슬라이드부는 열처리, 연마 강을 사용<br>와이퍼 장치는 불순물을 배척하여<br>수명 향상                         |



# 3-AXIS Gantry Systems

SYSTEM

<b>3GK 15</b> 15kg	<b>3GK 30</b> 30kg	<b>3GK 60</b> 60kg				
-----------------------	-----------------------	-----------------------	--	--	--	--

Type	Max. Pay Load	Max. Speed(m/min)			Acceleration(m/s <sup>2</sup> )			Repeatability (mm)
		X	Y	Z	X	Y	Z	
3GK 15	15kg	150	120	50	5	3	2	±0.1

Beam Size			Rack			Pinion			Gearbox		
X	Y	Z	X	Y	Z	X	Y	Z	X	Y	Z
SP150-20RP	AP80-16RP	AP166-30RP	Pitch: 7.5 Width: 25	Pitch: 5 Width: 20	Pitch: 5 Width: 15	Pitch: 7.5 Teeth: 20	Pitch: 5 Teeth: 20	Pitch: 5 Teeth: 15	FH045 (3:1)	FH045 (3:1)	FH045 (5:1)

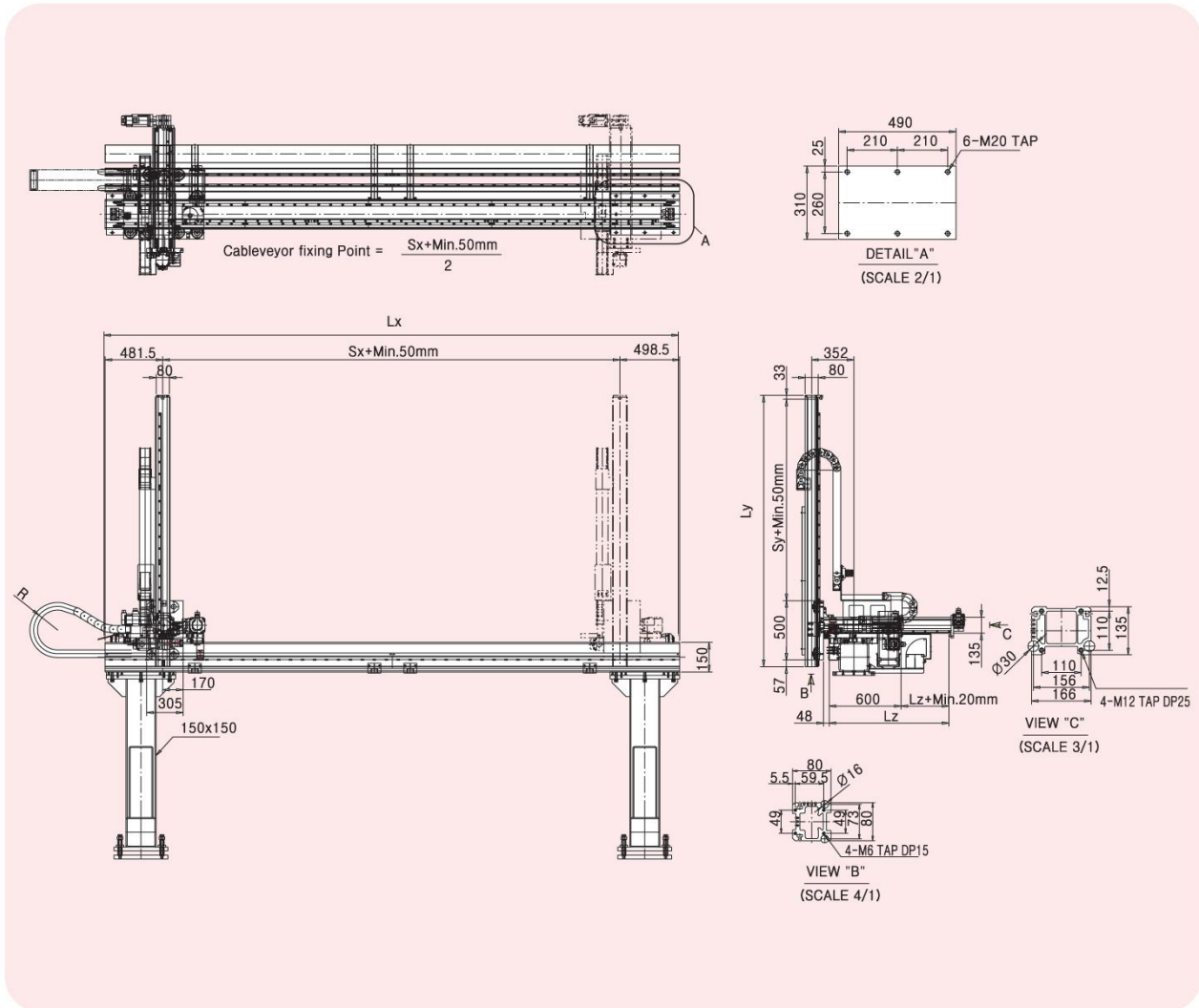



# 3-AXIS Gantry Systems

**3GK 15**  
15kg

**3GK 30**  
30kg

**3GK 60**  
60kg



Type	Max. Pay Load	Max. Speed(m/min)			Acceleration(m/s <sup>2</sup> )			Repeatability (mm)
		X	Y	Z	X	Y	Z	
3GK 30	30kg	150	120	50	5	3	2	±0.1

Beam Size			Rack			Pinion			Gearbox		
X	Y	Z	X	Y	Z	X	Y	Z	X	Y	Z
SP200-30RP	AP110-20RP	AP166-30RP	Pitch: 7.5 Width: 25	Pitch: 7.5 Width: 25	Pitch: 5 Width: 15	Pitch: 7.5 Teeth: 20	Pitch: 7.5 Teeth: 20	Pitch: 5 Teeth: 15	FH060 (3:1)	FH045 (3:1)	FH045 (5:1)

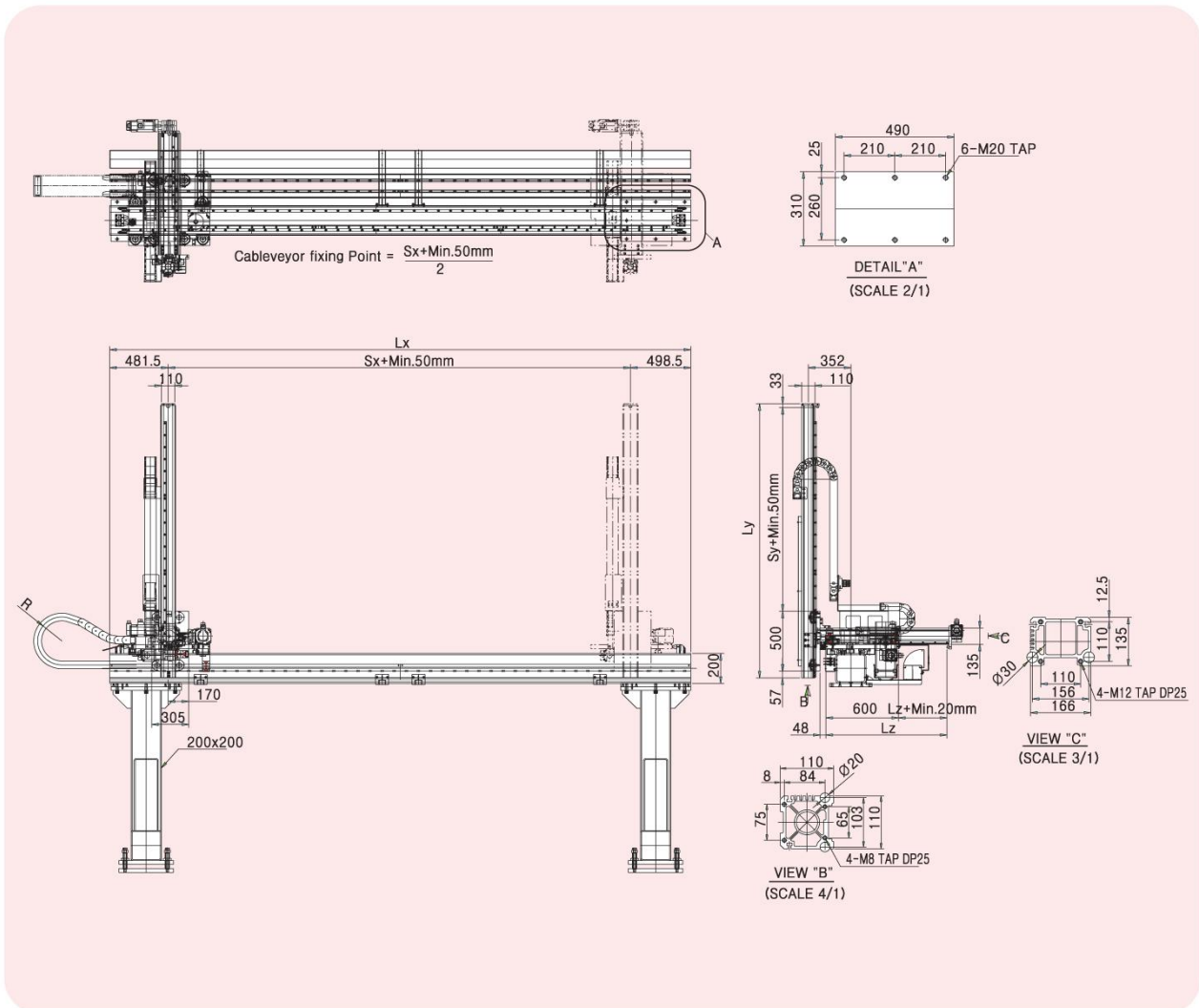

<b>3GK 15</b> 15kg	<b>3GK 30</b> 30kg	<b>3GK 60</b> 60kg				
-----------------------	-----------------------	-----------------------	--	--	--	--

Type	Max. Pay Load	Max. Speed(m/min)			Acceleration(m/s <sup>2</sup> )			Repeatability (mm)
		X	Y	Z	X	Y	Z	
3GK 60	60kg	150	120	50	5	3	2	±0.1

Beam Size			Rack			Pinion			Gearbox		
X	Y	Z	X	Y	Z	X	Y	Z	X	Y	Z
SP250-30RP	AP110-20RP	AP166-30RP	Pitch: 10 Width: 30	Pitch: 7.5 Width: 25	Pitch: 5 Width: 15	Pitch: 10 Teeth: 20	Pitch: 7.5 Teeth: 20	Pitch: 5 Teeth: 15	FH060 (3:1)	FH045 (3:1)	FH045 (5:1)

